

FITTING INSTRUCTION

Clamp mark in acc. with		Cables joining
ISO	PN	
1	L	Left directional lights
2	+	Rear fog lights
3	31	Ground
4	R	Right directional lights
5	58R	Right side parking lights
6	54	Stoplights
7	58L	Left side parking lights

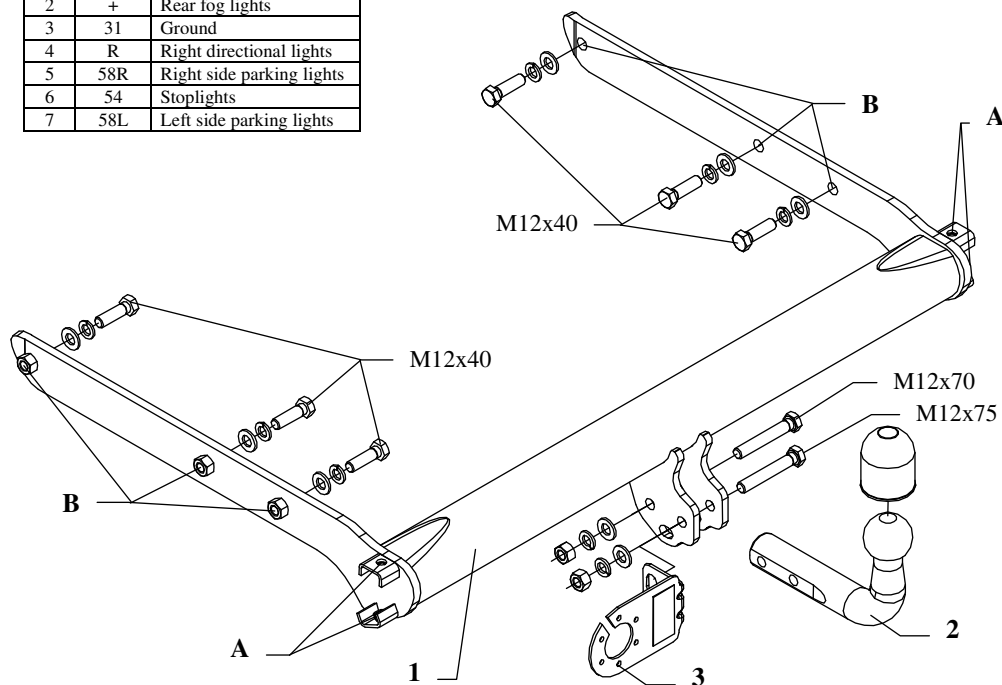

This towbar is designed to assembly in following cars:
VOLKSWAGEN T4 TRANSPORTER, 4x4, 2x4, produced since 08.1990 till 01.1996, catalogue no. **K12** and is prepared to tow trailers max total weight **2500 kg** and max vertical mass **100 kg**.

From manufacturer

Thank you for buying our product. Their reliability has been confirmed in many tests. Reliability of towbar depends also on correct assembly and right operation. For this reasons we kindly ask to read carefully this instruction and apply to hints.

The towbar should be install in points described by a car producer.

The instruction of the assembly

1. Disassemble a rear bumper, next unscrew its brackets.
2. Cut out fragment of bumper – from below, in his axis, width 50mm and length 40mm.
3. Through holes (pos. A) fix main bar of the towbar (pos. 1) with bumper using original bolts from unscrewed bumper brackets.
4. In this way prepared assembly (towbar with bumper) mount to car frame through holes (pos. B) using bolts M12x40mm (pos. 6) from towbar accessories.
5. Tighten all bolts according to the torque shown in the table.
6. Fix tow-ball (pos. 2) and socket plate (pos. 3) using bolts M12x75mm (pos. 4) and M12x70mm (pos. 5) from accessories.
7. Connect electric wires of 7-poles socket according to the instruction of the car. (Recommend to make at authorized service station).
8. Complete paint layer damaged during installation.

Torque settings for nuts and bolts (8,8):	
M 8 - 25 Nm	M 10 - 55 Nm
M 12 - 85 Nm	M 14 - 135 Nm

NOTE

After install the towbar you should get adequate note in registration book (at authorised service station).The car should be equipped with:

- Indicators
- Tow mirrors

After 1000km of exploitation check all bolts and nuts. The ball of towbar must be always kept clear and conserve with a grease.

Towbar accessories:

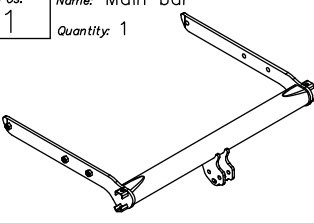
Pos. 1	Name: Main bar Quantity: 1	Pos. 4	Name: Bolt 8,8 B Quantity: 1 Dim.: M12x75mm	Pos. 8	Name: Plain washer Quantity: 8 Dim.: Ø 13 mm
		Pos. 5	Name: Bolt 8,8 B Quantity: 1 Dim.: M12x70mm	Pos. 9	Name: Spring washer Quantity: 8 Dim.: Ø 12,2 mm
Pos. 2	Name: Tow ball Quantity: 1	Pos. 6	Name: Bolt 8,8 B Quantity: 6 Dim.: M12x40 mm	Pos. 10	Name: Ball cover Quantity: 1
Pos. 3	Name: Socket plate Quantity: 1	Pos. 7	Name: Nut 8 B Quantity: 2 Dim.: M12		



PPUH AUTO-HAK S.J.

Produkcja Zaczepów Kulowych
Henryk & Zbigniew Nejman
76-200 SŁUPSK ul. Słoneczna 16K
tel/fax (059) 8-414-414; 8-414-413
E-mail: office@autohak.com.pl
www.autohak.com.pl

Towing hitch (without electrical set)

Class: **A50-X** Cat. no. **K12**

Designed for:

Manufacturer: **VOLKSWAGEN**

Model: **T4 TRANSPORTER**

Type: **4x4, 2x4**

produced since 08.1990 till 01.1996

Technical data:

D-value: 12,9 kN

maximum trailer weight: **2500 kg**

maximum vertical cup mass: **100 kg**

Approval number acc. to regulations EKG/ONZ 55.01: **E20-55R-01 1345**

Foreword

This towbar is designed according to rules of safety traffic regulations. The towing hitch is a safety component and can be install only by qualified personnel. Any alteration or conversion of the towing hitch is prohibited and would lead to cancellation of design certification. Remove insulating compound and underseal from vehicle (if present) in the area of the matting surfaces of the towing hitch. The vehicle manufacturer's specifications regarding trailer load and max. vertical cup load are decisive for driving whereat values for the towing hitch cannot be exceeded.

D-value formula:

$$\frac{\text{Max trailer weight [kg]} \times \text{Max vehicle weight [kg]}}{\text{Max trailer weight [kg]} + \text{Max vehicle weight [kg]}} \times \frac{9,81}{1000} = D \text{ [kN]}$$



ahkupplungen.de