

FITTING INSTRUCTION

Clamp mark in acc. with		Cables joining
ISO	PN	
1	L	Left directional lights
2	+	Rear fog lights
3	31	Ground
4	R	Right directional lights
5	58R	Right side parking lights
6	54	Stoplights
7	58L	Left side parking lights

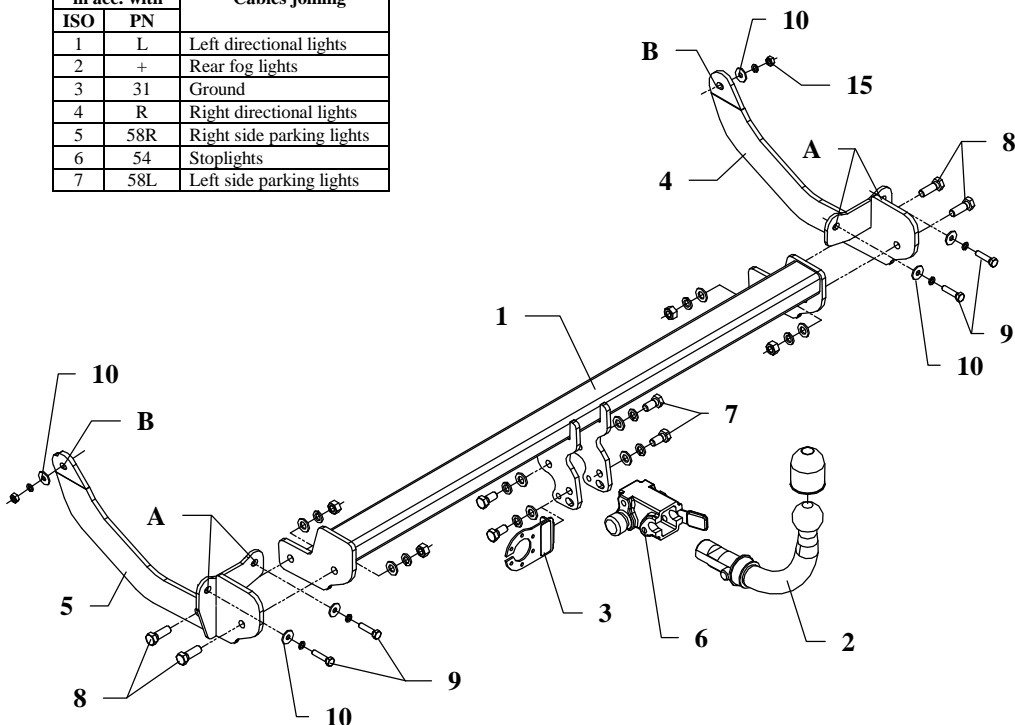

This towing hitch is designed to assembly in following cars: **PEUEOT 308SW (estate)**, produced since 2008, catalogue number **F33A** and is prepared to tow trailers max total weight **1700 kg** and max vertical mass **75 kg**.

From manufacturer

Thank you for buying our product. Their reliability has been confirmed in many tests. Reliability of towing hitch depends also on correct assembly and right operation. For this reasons we kindly ask to read carefully this instruction and apply to hints.

The towing hitch should be install in points described by a car producer.

The instruction of the assembly

1. Underneath disassemble original towing eyes from chassis members.
2. From chassis disassemble plastic handles of bumper.
3. Twist off last, plastic covers of chassis and deflect it down.
4. Disassemble last handle of muffler.
5. Under bowl of bumper situated metal reinforcement. Twist off per two lower bolts of reinforcement.
6. To places after original bolts apply side brackets (pos. 4 and 5) and fix it through holes A by bolts M8x35mm (pos. 9). From outside of chassis members apply brackets through holes B on protruding, threaded pins and fix it by nuts M8 and big washers (pos. 10 and 15).
7. Between installed side brackets apply main bar of the towbar (pos. 1) and fix by bolts M12x35mm (pos. 8).
8. Fix body of the automat (pos. 6) and the socket plate (pos. 3) using bolts M12x25mm (pos. 7) from accessories. Place tow-ball (pos. 2) according to supplied instruction.
9. Tighten all bolts according to the torque shown in the table.
10. Reassemble elements disassembled at points 2, 3 and 4.
11. Connect electric wires of 7-poles socket according to the instruction of the car. (Recommend to make at authorized service station).
12. Complete paint layer damaged during installation.

Torque settings for nuts and bolts (8,8):	
M 8 - 25 Nm	M 10 - 55 Nm
M 12 - 85 Nm	M 14 - 135 Nm

NOTE

After install the towing hitch you should get adequate note in registration book (at authorised service station). The car should be equipped with:

- Indicators
- Tow mirrors

After 1000km of exploitation check all bolts and nuts. The ball of towing hitch must be always kept clear and conserve with a grease.

Towing hitch accessories:

Pos. 1 Main bar PCS.: 1	Pos. 5 Left bracket PCS.: 1	Pos. 11 Plain washer ø13mm PCS.: 8
		Pos. 12 Spring washer ø12,2mm PCS.: 8
Pos. 2 Tow ball PCS.: 1	Pos. 6 Body of the automat PCS.: 1	Pos. 13 Spring washer ø8,2mm PCS.: 6
Pos. 3 Socket plate PCS.: 1	Pos. 7 Bolt 8,8 B M12x25mm PCS.: 4	Pos. 14 Nut 8 B M12 PCS.: 4
Pos. 4 Right bracket PCS.: 1	Pos. 8 Bolt 8,8 B M12x35mm PCS.: 4	Pos. 15 Nut 8 B M8 PCS.: 2
	Pos. 9 Bolt 8,8 B M8x35mm PCS.: 4	Pos. 16 Ball cover PCS.: 1
	Pos. 10 Washer ø24xø8,4x2mm PCS.: 6	Pos. 17 Body plug PCS.: 1



PPUH AUTO-HAK S.J.

Produkcja Zaczepów Kulowych
Henryk & Zbigniew Nejman
76-200 SŁUPSK ul. Słoneczna 16K
tel/fax (059) 8-414-414; 8-414-413
E-mail: office@autohak.com.pl
www.autohak.com.pl

Towing hitch (without electrical set)

Class: **A50-X** Cat. no. **F33A**

Designed for:

Manufacturer: **PEUGEOT**

Model: **308**

Type: **SW (estate)**

produced since 2008

Technical data:

D-value: 9,6 kN

maximum trailer weight: **1700 kg**

maximum vertical cup mass: **75 kg**

Approval number according to Directive 94/20/EC: **e20*94/20*0537*00**

Foreword

This towing hitch is designed according to rules of safety traffic regulations. The towing hitch is a safety component and can be install only by qualified personnel. Any alteration or conversion of the towing hitch is prohibited and would lead to cancellation of design certification. Remove insulating compound and underseal from vehicle (if present) in the area of the matting surfaces of the towing hitch. The vehicle manufacturer's specifications regarding trailer mass and max. vertical cup mass are decisive for driving whereat values for the towing hitch cannot be exceeded.

D-value formula:

$$\frac{\text{Max trailer weight [kg]} \times \text{Max vehicle weight [kg]}}{\text{Max trailer weight [kg]} + \text{Max vehicle weight [kg]}} \times \frac{9,81}{1000} = D \text{ [kN]}$$



ahkupplungen.de