

ISTRUZIONI DI MONTAGGIO

FITTING INSTRUCTIONS

INSTRUCTIONS DE MONTAGE

MONTAGEANLEITUNG

INSTRUCCIONES DE MONTAJE



www.umbrarimorchi.it

umbrarimorchi@umbrarimorchi.it

tel. +39 075 5280260

fax +39 075 5287033

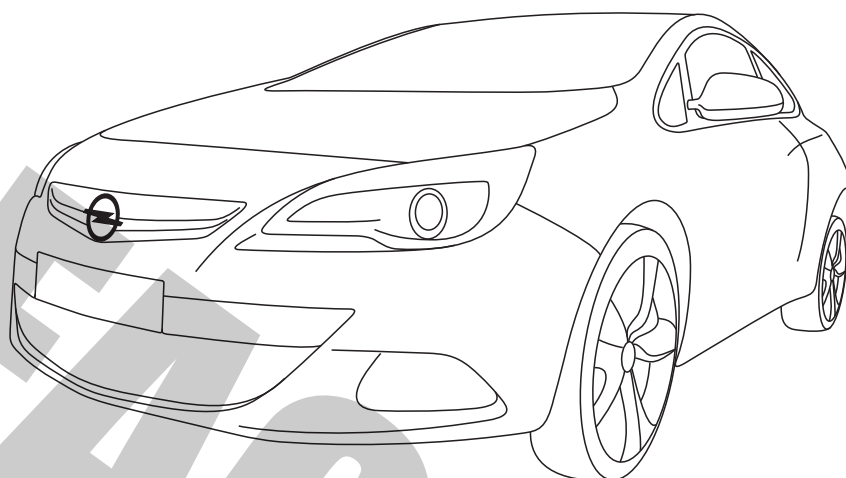

NR.ART. 28062/F

DISPOSITIVO DI TRAIÑO TIPO TOWING BRACKET TYPE DISPOSITIF DE REMORQUAGE TYPE ANHAENGEVORRICHTUNG TYP DISPOSITIVO DE CAREO TIPO	28062
---	--------------

PER AUTOVEICOLI FOR CARS POUR AUTOS FÜR KRAFTFAHRZEUGE PARA AUTOVEHICULO	OPEL ASTRA GTC	
TYPE	P-J/SW	2012 →
CLASSE E TIPO DI ATTACCO CLASS AND HITCH TYPE CLASSE ET TYPE DE CROCHET KLASSE UND BEFESTIGUNGSART CLASES DE ACOPLAMIENTO	OMOLOGAZIONE HOMOLOGATION HOMOLOGATION ZULASSUNG APROBACION	CARICO VERTICALE MAX MAX VERTICAL MASS MASSE VERTICALE MAXIMUM ZUL. STUETZLAST CARGA MAX. VERTICAL
F	e3 00 – 7651 (DIR. 94/20/CE)	S = 90 kg
VALORE D D VALUE VALEUR D D WERT VALOR D	D = 9,8 kN	$D = \frac{\text{Max } \downarrow \text{ Kg} \times \text{Max } \downarrow \text{ Kg}}{\text{Max } \downarrow \text{ Kg} + \text{Max } \downarrow \text{ Kg}} \times 0,00981 \leq 9,8 \text{ kN}$

COPPIA DI SERRAGGIO PER VITI (8.8): TORQUE SETTINGS FOR NUTS AND BOLTS (8.8): COUPLE DE SERRAGE POUR VIS (8.8): SCHRAUBENZUGSMOMENT (8.8): MOM. DE PRESION PARA TORNILLOS Y TUERCAS (8.8):	M6 = 10 Nm M8 = 25 Nm M10 = 55 Nm M12 = 85 Nm M14 = 135 Nm M16 = 200 Nm
---	---

NOTE IMPORTANTI:

1. Prima dell'installazione assicurarsi che il dispositivo di traino in oggetto sia adatto per il veicolo sul quale lo si intende installare; verificare che il tipo funzionale dell'autoveicolo, riportato sulla carta di circolazione nei punti D.1 / D.2, esista sul documento del gancio traino. In caso contrario consultare l'ufficio documenti per chiarimenti o richiesta di documenti aggiornati.
2. Il dispositivo di traino è un elemento di sicurezza e come tale deve essere installato solamente da un tecnico specializzato.
3. Elementi danneggiati o usurati devono essere sostituiti con ricambi originali da un tecnico specializzato.
4. E' proibito effettuare qualsiasi tipo di modifica significativa o riparazione alla struttura del dispositivo di traino.

USO E MANUTENZIONE:

5. La sfera del dispositivo di traino deve essere mantenuta pulita e lubrificata. Per la massima sicurezza controllare saltuariamente il diametro della sfera; qualora il diametro della stessa, in diversi punti, sia ridotto a 49 mm il dispositivo di traino non potrà essere più utilizzato sino alla sostituzione della sopra citata sfera.
6. Dopo 1000 Km di traino tutta la bulloneria del dispositivo di traino deve essere controllata e riportata al valore di coppia di serraggio come indicato nella pagina delle istruzioni di montaggio.

ATTENZIONE :

L'installatore del gancio di traino ha l'obbligo di fissare, all'altezza della sfera, in posizione ben visibile, una targhetta con l'indicazione del carico massimo sulla sfera prescritto per la vettura sulla quale viene montato il dispositivo di traino.

DISPOSITIVO DI TRAINO TIPO : 28062
TIPO FUNZIONALE : P-J/SW ??????? ???????????
CARICO STATICO SU SFERA : 75 Kg
LARGHEZZA MAX RIMORCHIABILE : 2,55 m
MASSA RIMORCHIABILE : (vedere nella carta di circolazione del veicolo)

DA COMPILARE PER IL COLLAUDO



DICHIARAZIONE DI RESPONSABILITA' PER IL MONTAGGIO :

Si dichiara che il presente dispositivo di traino tipo..... è stato montato a regola d'arte, rispettando le prescrizioni fornite sia del costruttore del veicolo che del costruttore del dispositivo di traino, sull'autoveicolo modello..... con targa.....

....., lì (timbro e firma)

Si dichiara inoltre di aver informato l'utente del veicolo sull'USO e MANUTENZIONE del dispositivo stesso.

28062/F

①	2x	M12x85 (8.8)	
②	2x	12.2x27x2.5	
③	2x	M12 (8.8)	

U.R. tipo SF12/N
Appr. Nr. e3 00-7672

(F55H)

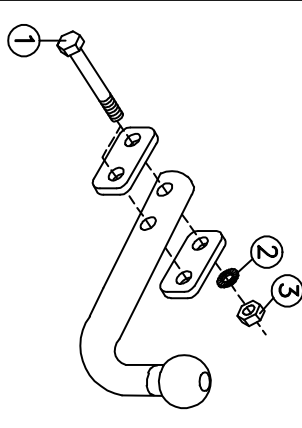
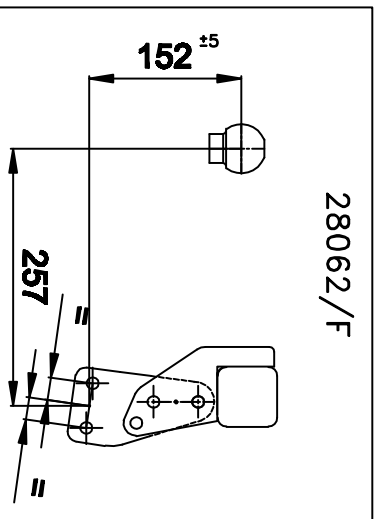
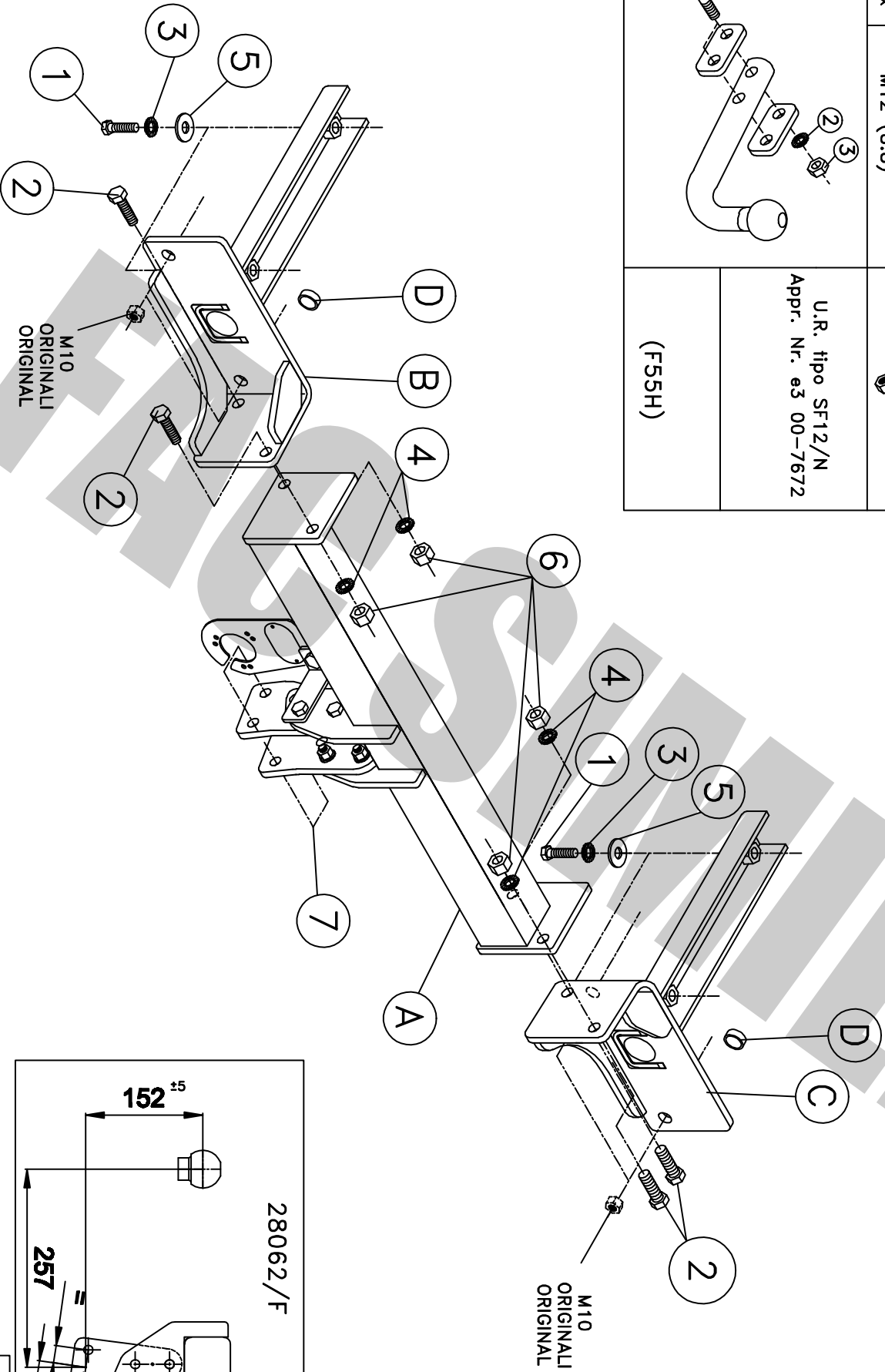









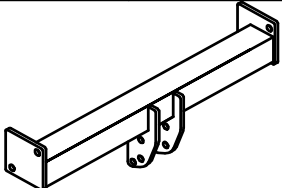
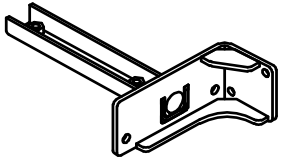
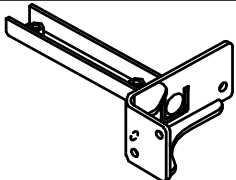

REV.00



UMBRA RIMORCHI
S. SISTO - PERUGIA

KIT COD. 28062

(A)	1x	28062.B03	
(B)	1x	28062.B04SX	
(C)	1x	28062.B04DX	
(D)	2x	28062.B08	 DIST. $\varnothing 22 \times 2 \times 8$
(1)	4x	M10x35 (8.8)	
(2)	4x	M12x35 (8.8)	
(3)	4x	10.2x22x2	
(4)	4x	12.2x27x2	
(5)	4x	10.2x30x2	
(6)	2x	M12 (8.8)	
(7)		M12	

REV.00

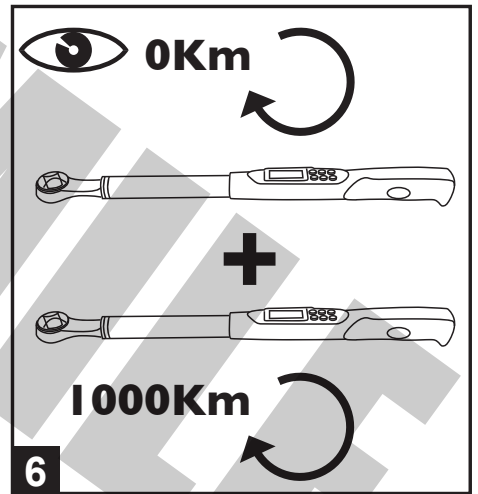
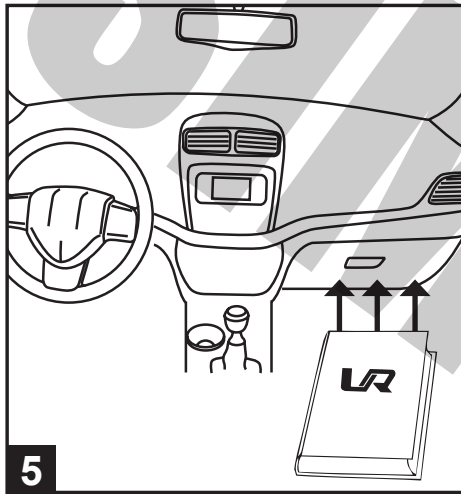
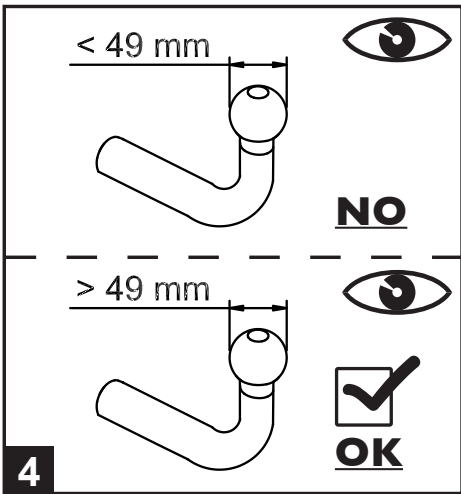
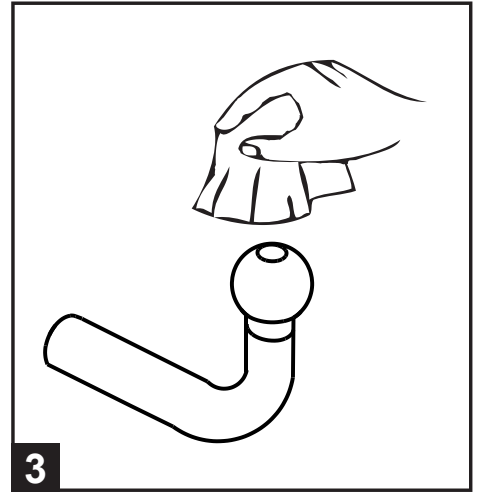
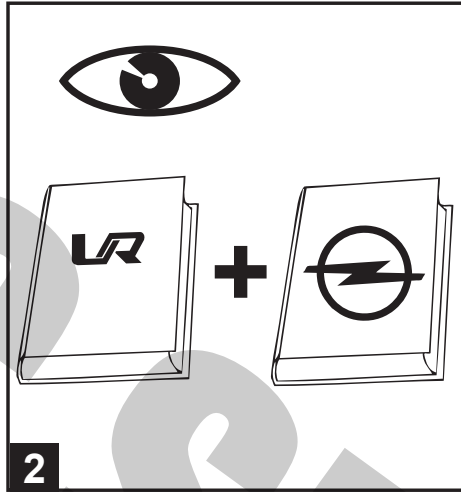
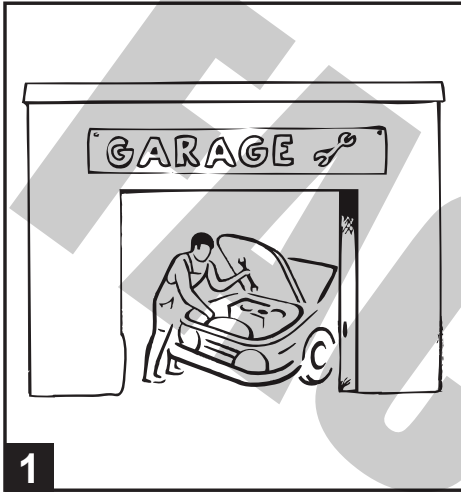

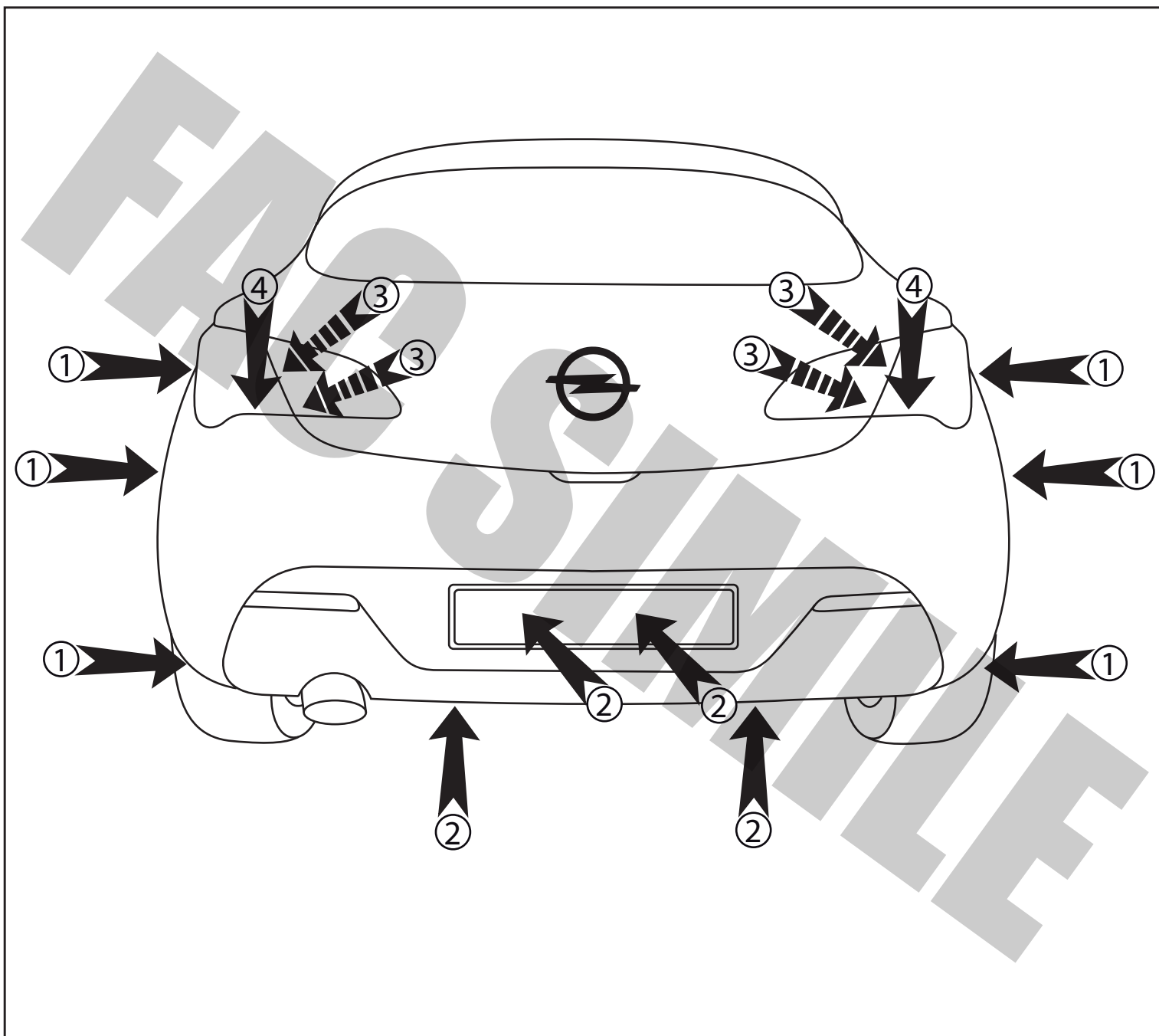

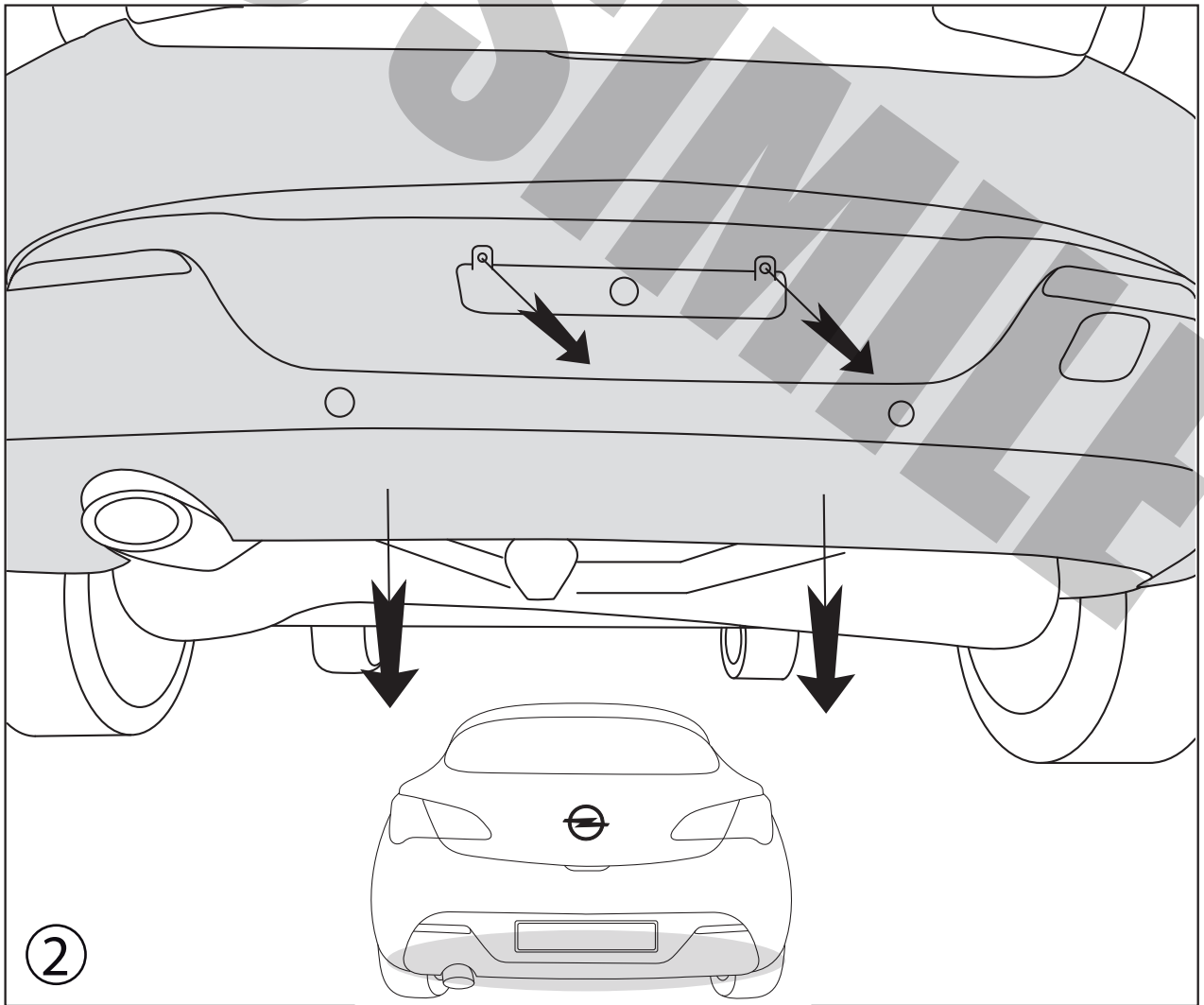
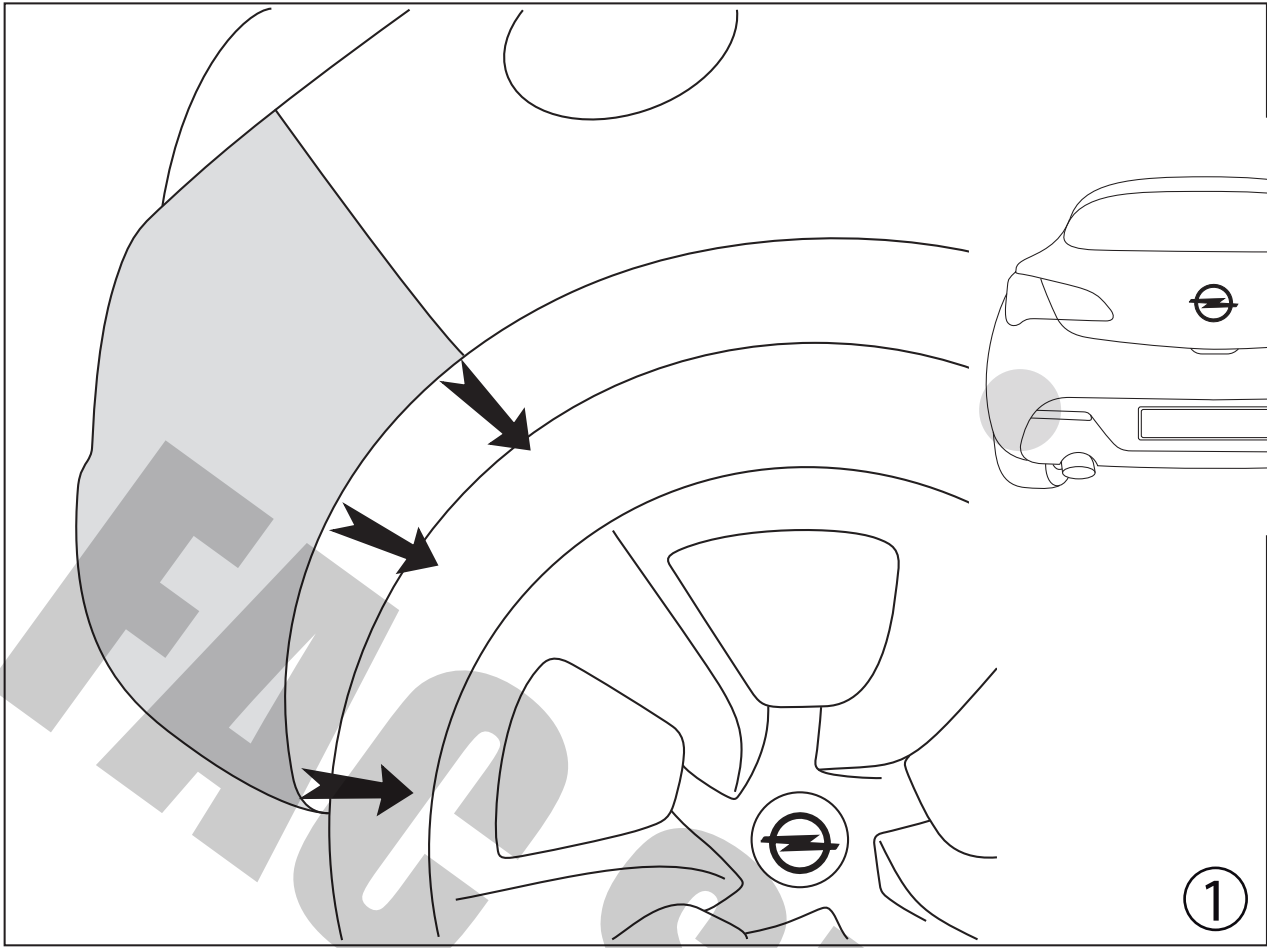

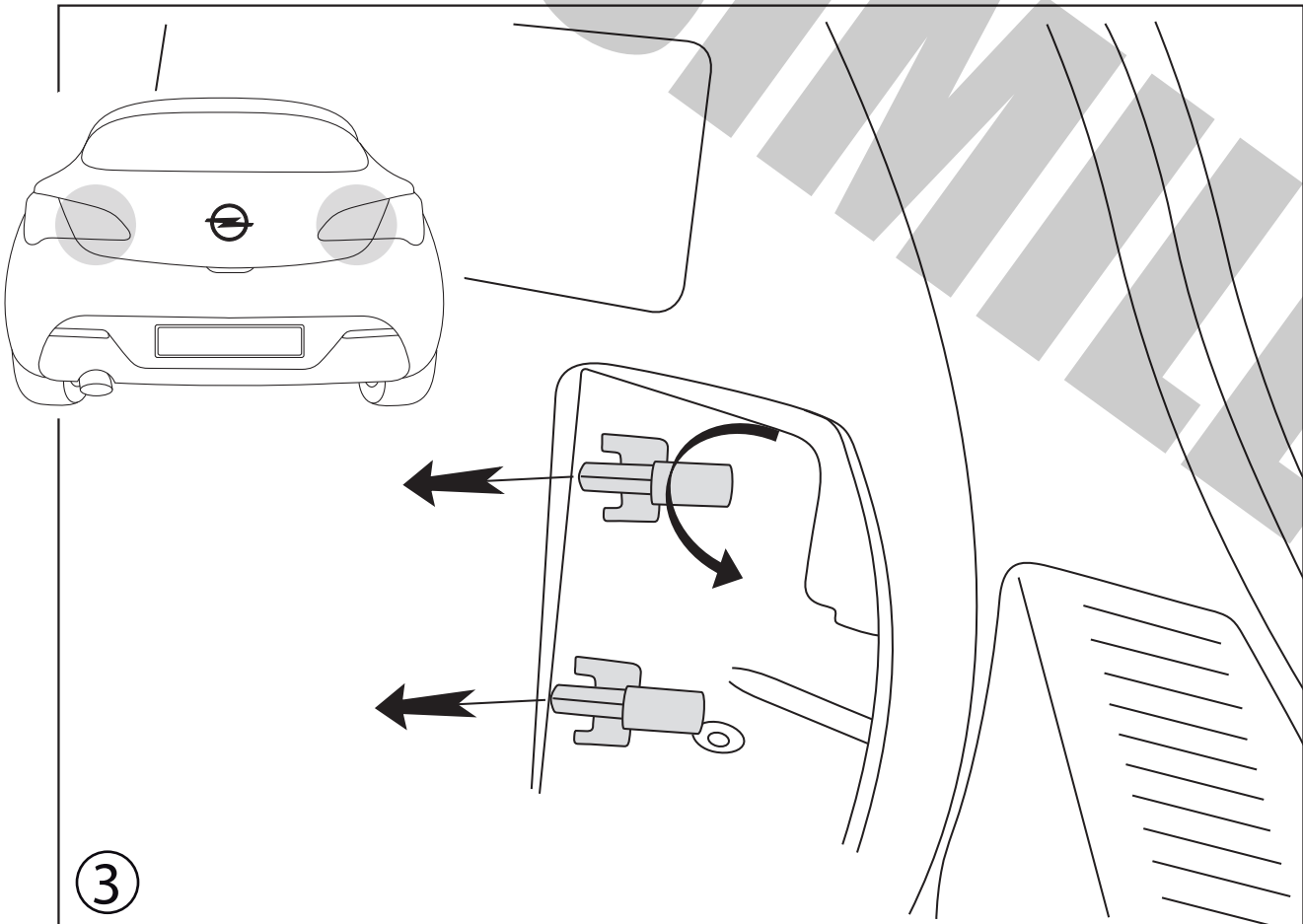
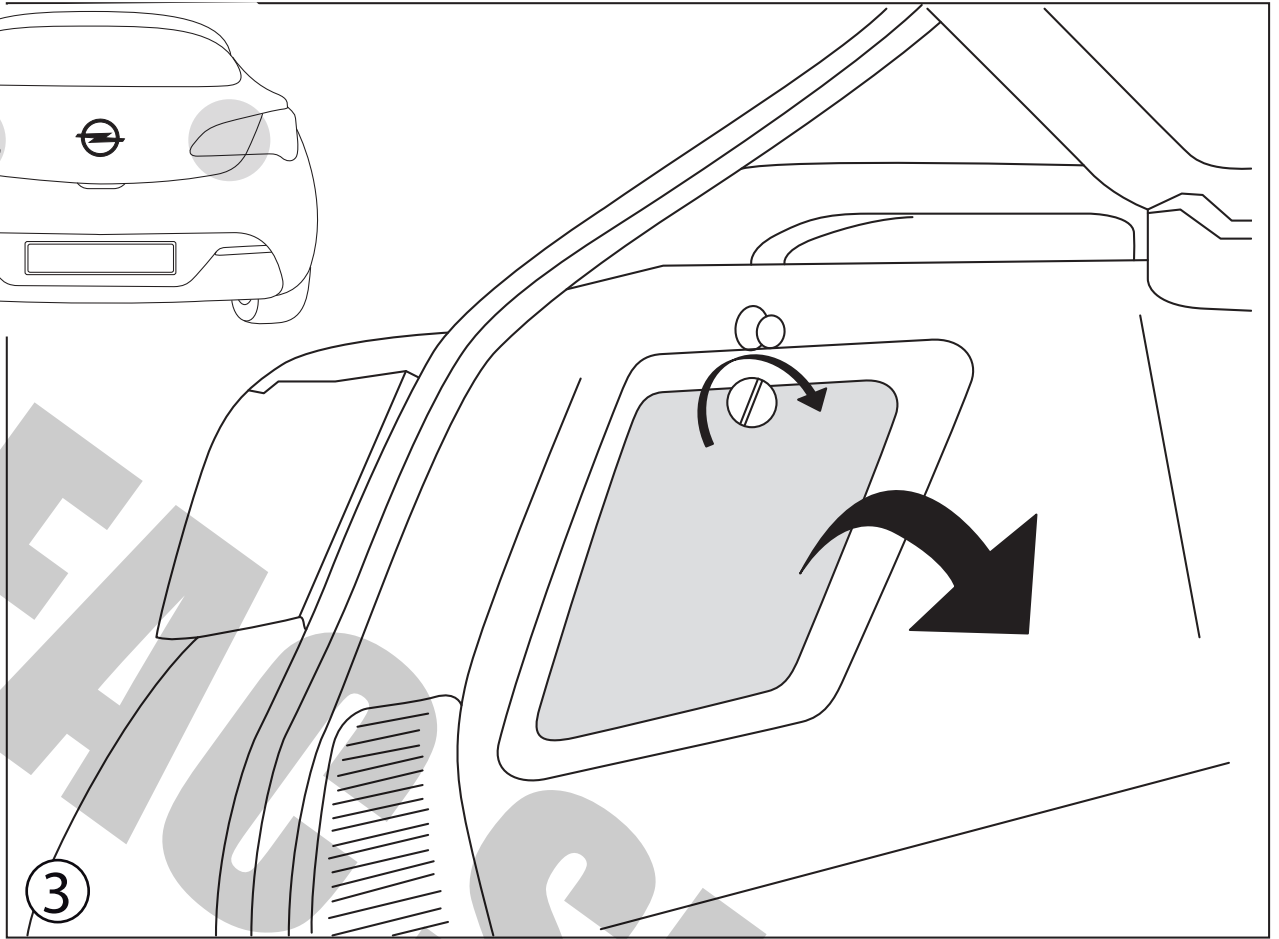
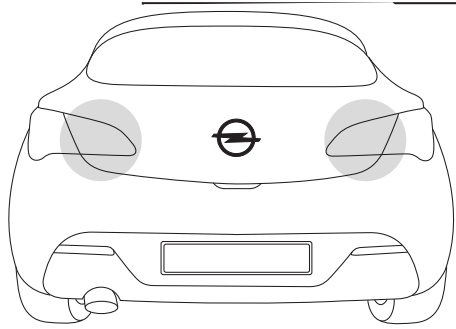

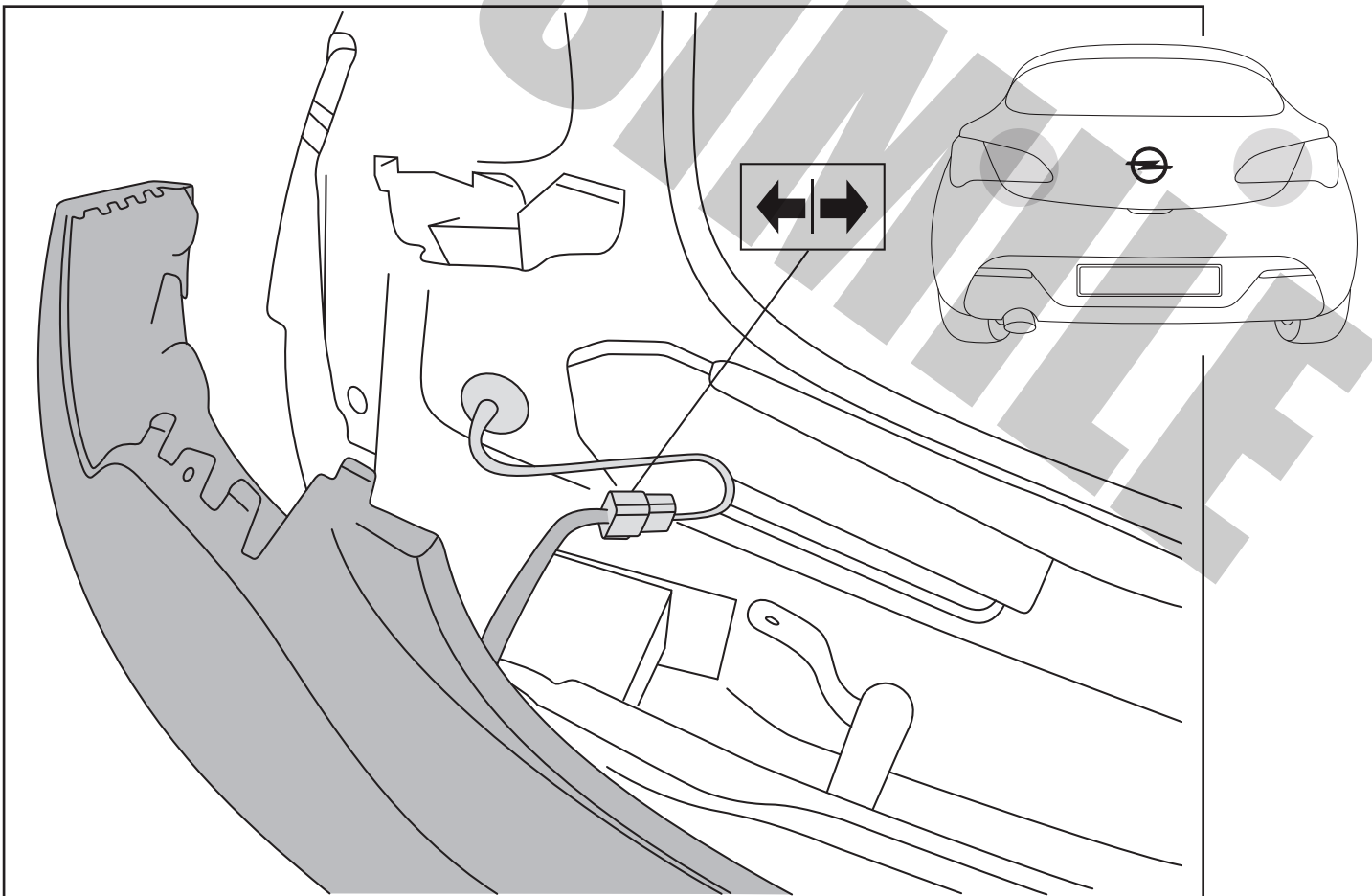
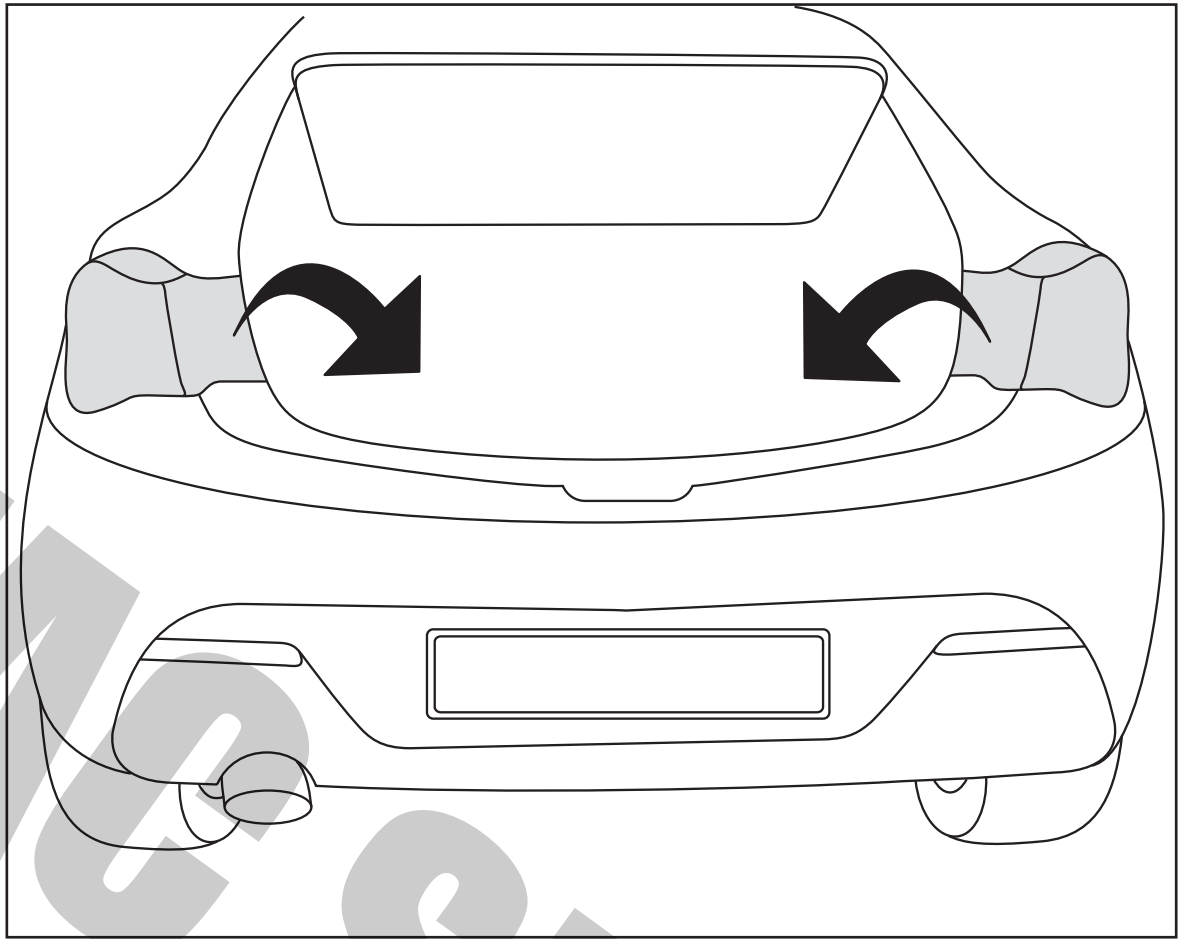

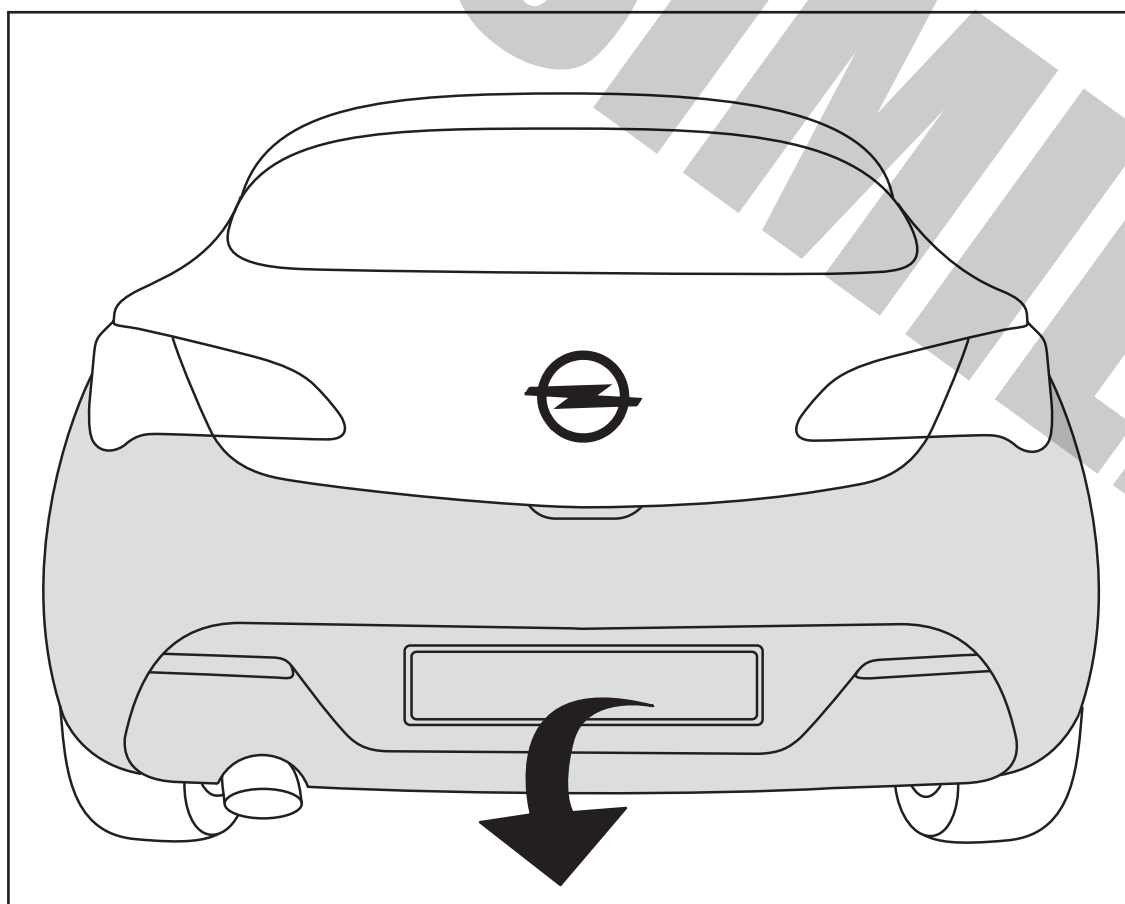
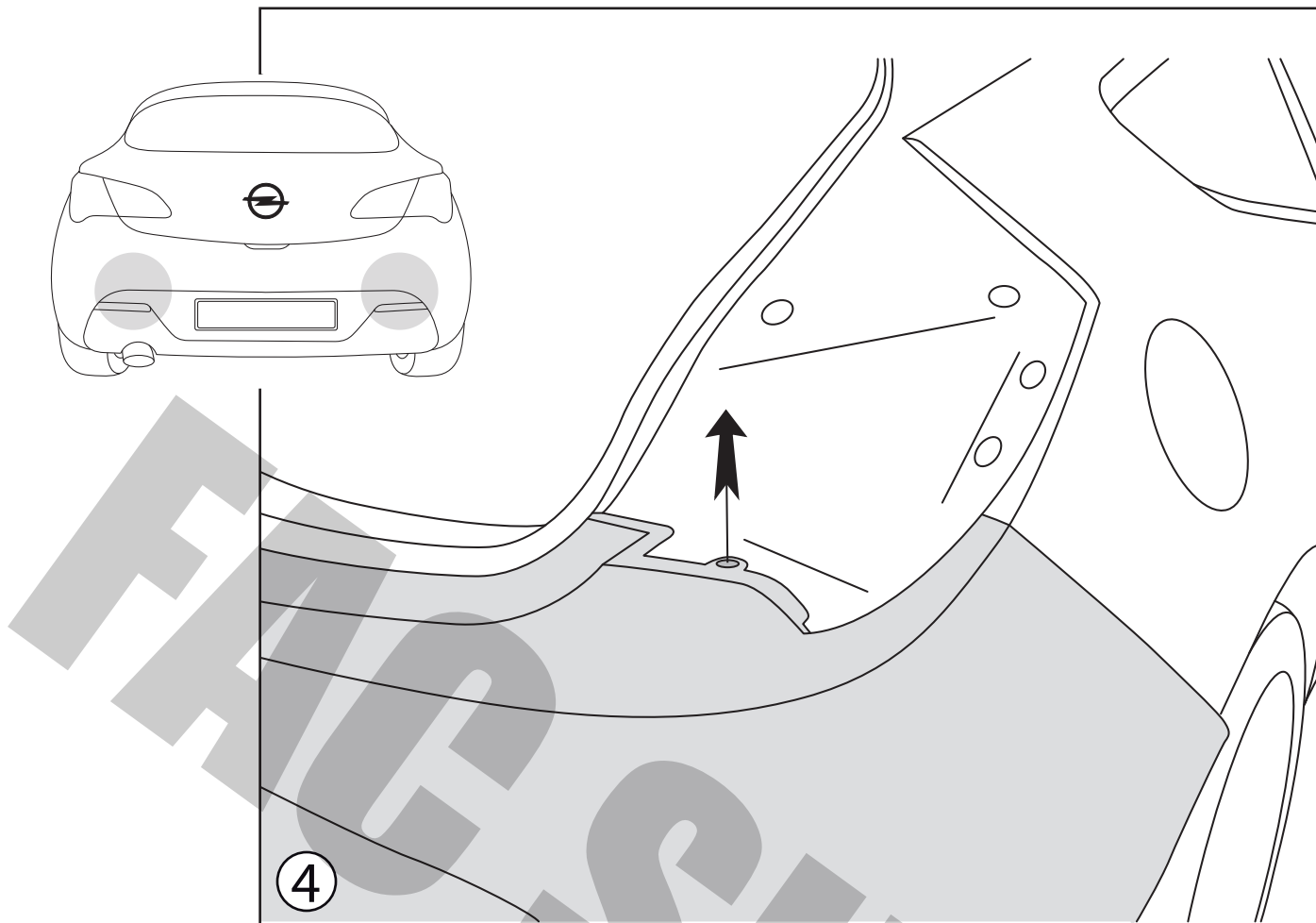

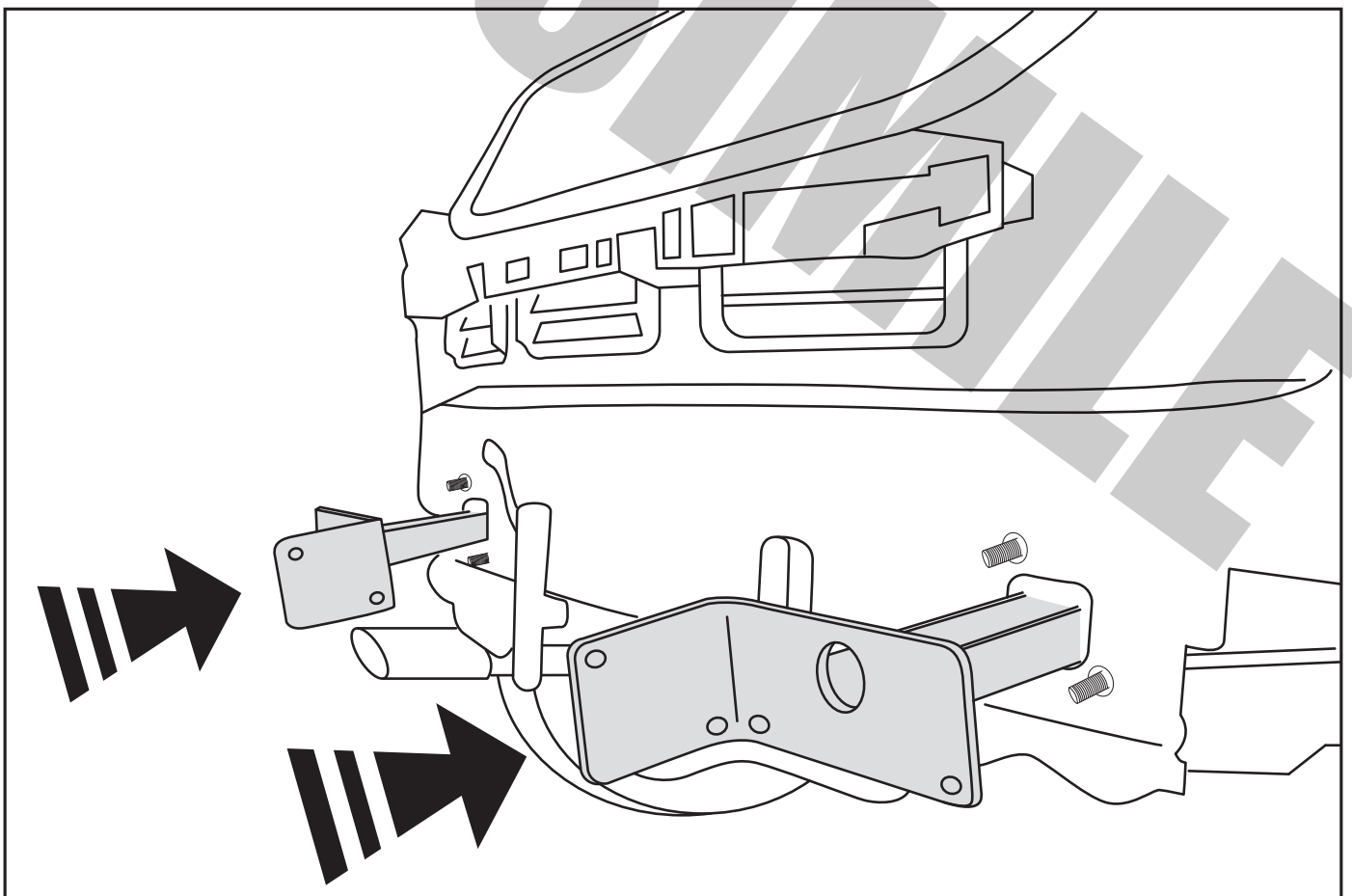
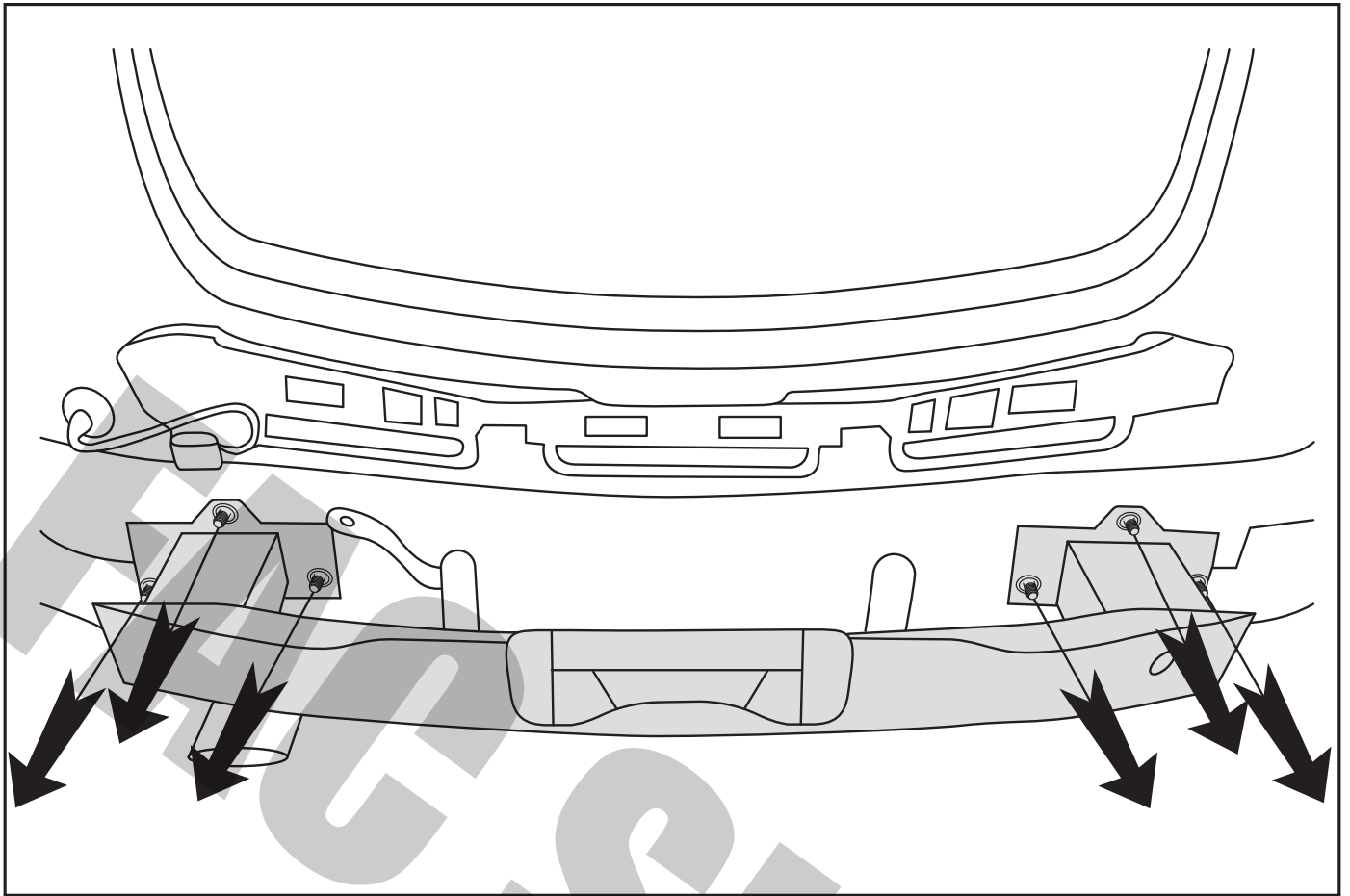

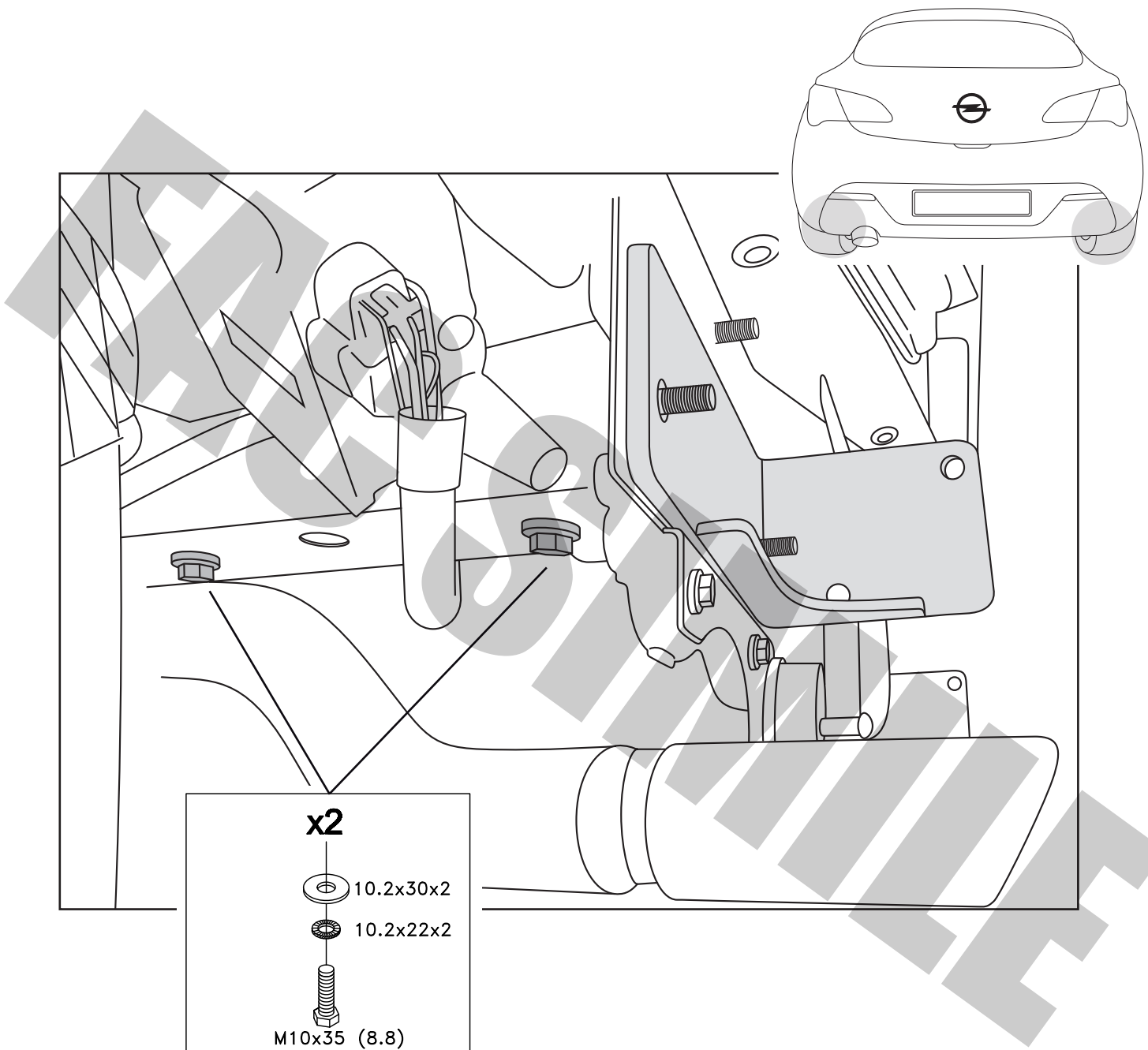

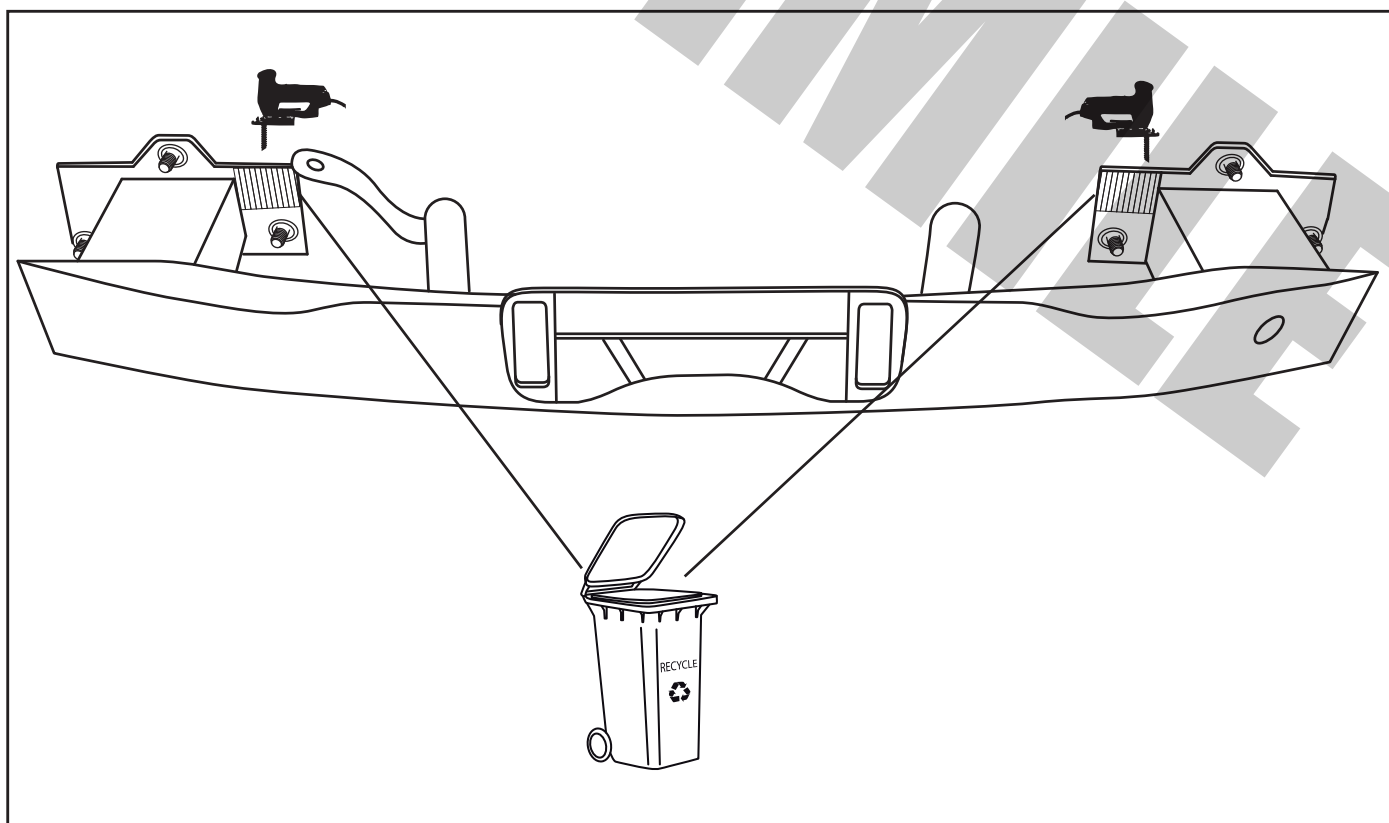
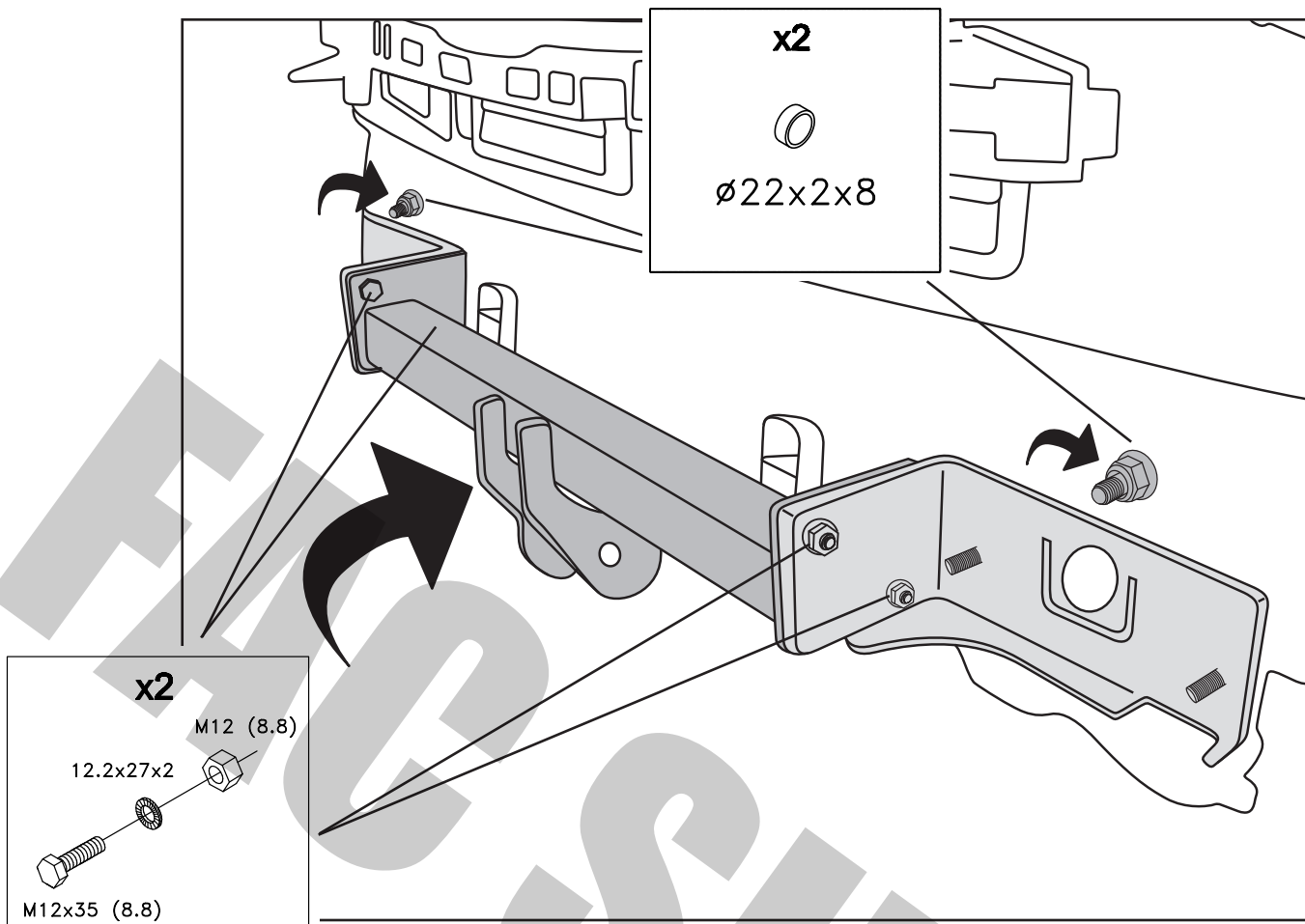

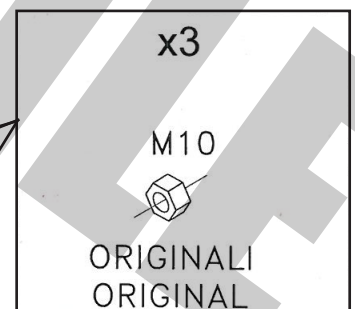
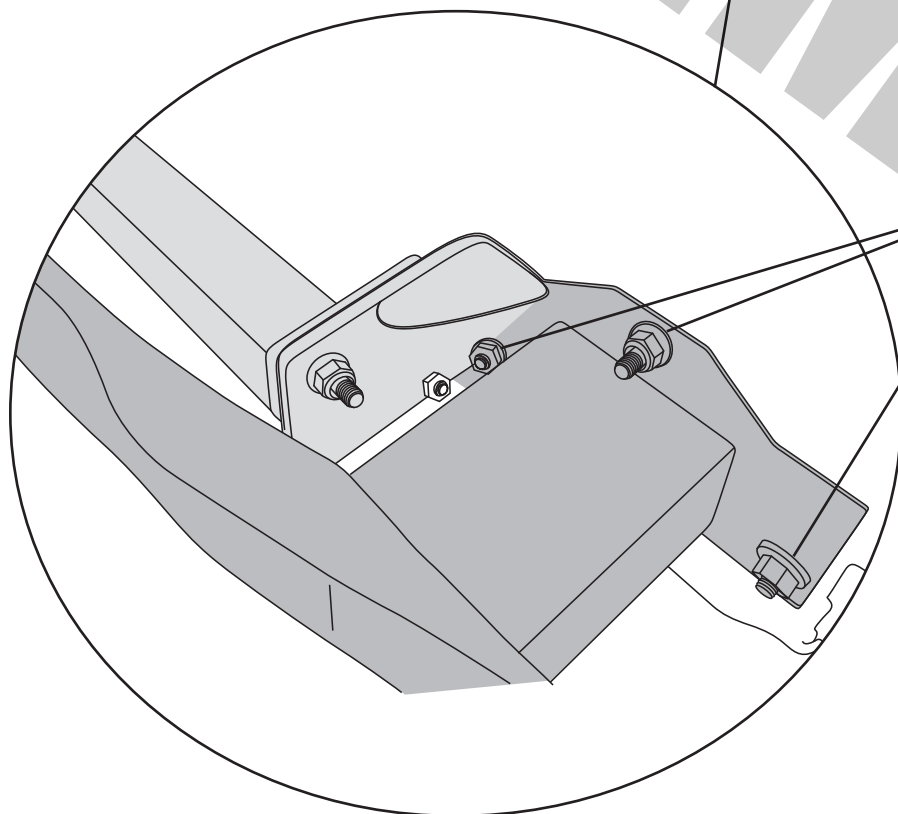
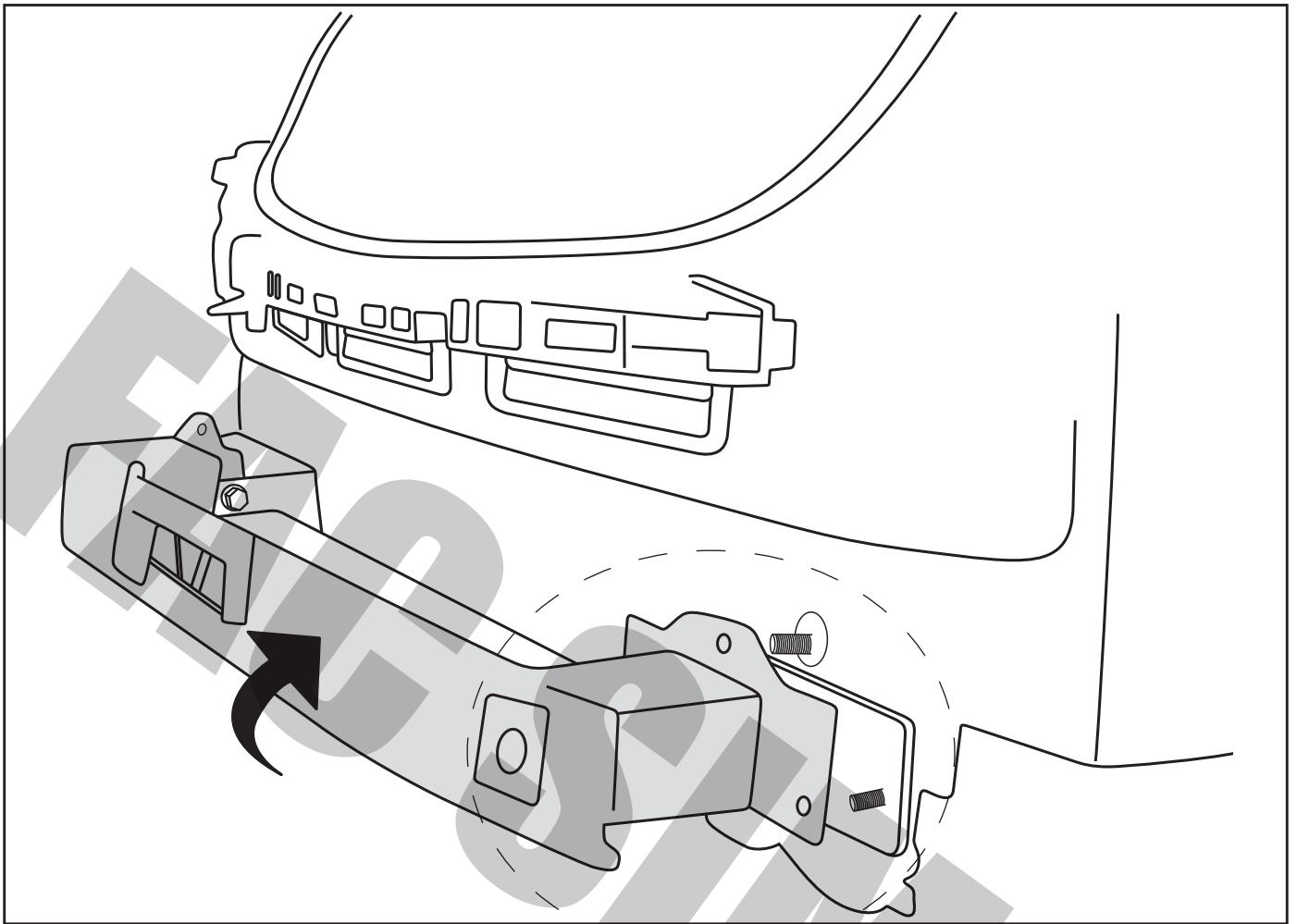

SCHEMA TAGLIO PARAURTI
BUMPER'S CUT SCHEMA

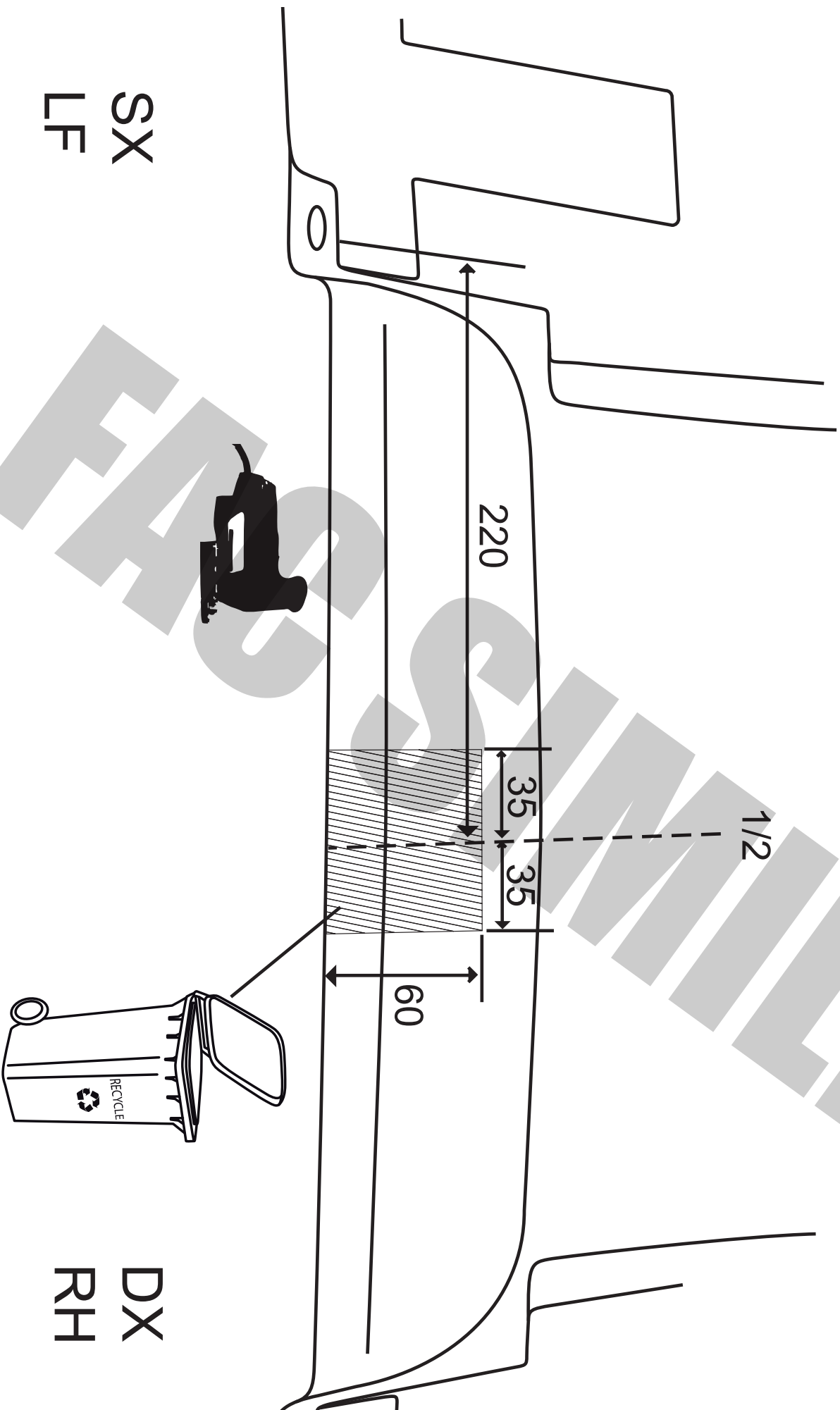

SX
LF

DX
RH

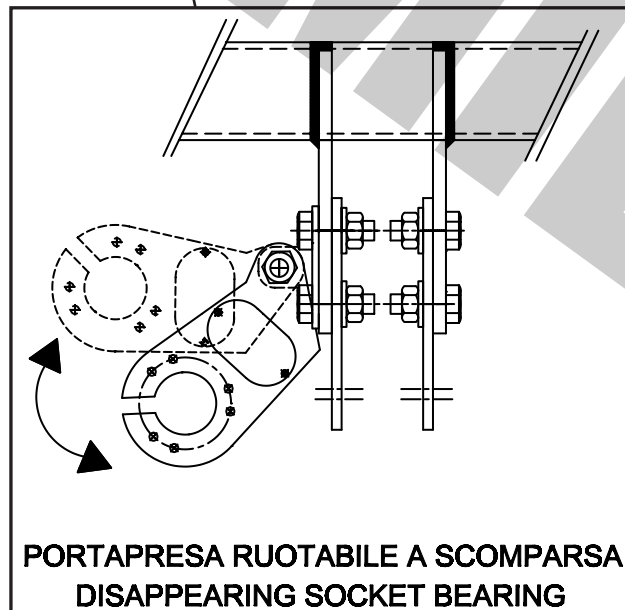
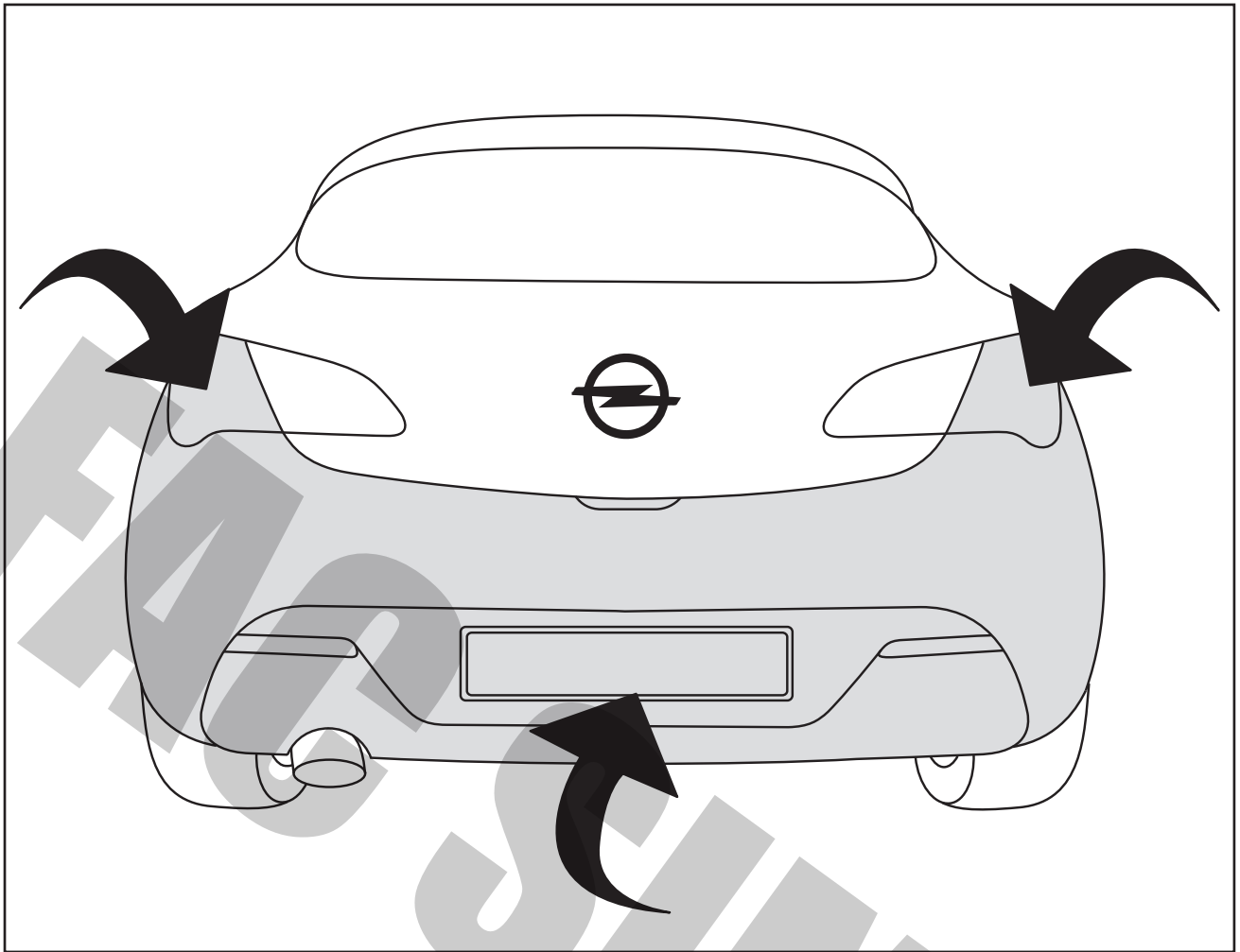

- D** Der Freiraum nach Anhang VII, Abbildung 30 der Richtlinie 94/20/EG ist zu gewährleisten.
- CZ** Volný prostor ve smyslu Přílohy VII, obr. 30 Směrnice č. 94/20/EG musí být zaručen.
- DK** Frirummet skal overholdes iht. bilag VII, fig. 30 i direktiv 94/20/EF.
- E** Debe garantizarse el espacio libre, conforme al anexo VII, imagen 30 de la directiva comunitaria 94/20/CE.
- F** L'espace libre doit être garanti conformément à l'annexe VII, illustration 30 de la directive 94/20/CE.
- FIN** Liitteen VII, direktiivin 94/20/EY kuvan 30 mukainen vapaatila on taattava.
- GB** The clearance specified in appendix VII, diagram 30 of guideline 94/20/EC must be guaranteed.
- GR** Πρέπει να εξασφαλίζεται ο ελεύθερος χώρος σύμφωνα με το Παράρτημα VII, εικόνα 30 της Οδηγίας 94/20/EK.
- I** Deve essere garantito lo spazio libero secondo l'allegato VII, figura 30 della direttiva 94/20/CE.
- N** Frirummet etter tillegg VII, figur 30 i direktiv 94/20/EØF skal overholdes.
- NL** De tussenruimte volgens aanhangsel VII, afbeelding 30 van de richtlijn 94/20/EG moet in acht worden genomen.
- PL** Zagwarantować swobodną przestrzeń zgodnie z załącznikiem VII, rysunek 30 dyrektywy 94/20/CE.
- S** Glappet enligt bilaga VII, bild 30 i direktiv 94/20/EG ska garanteras.

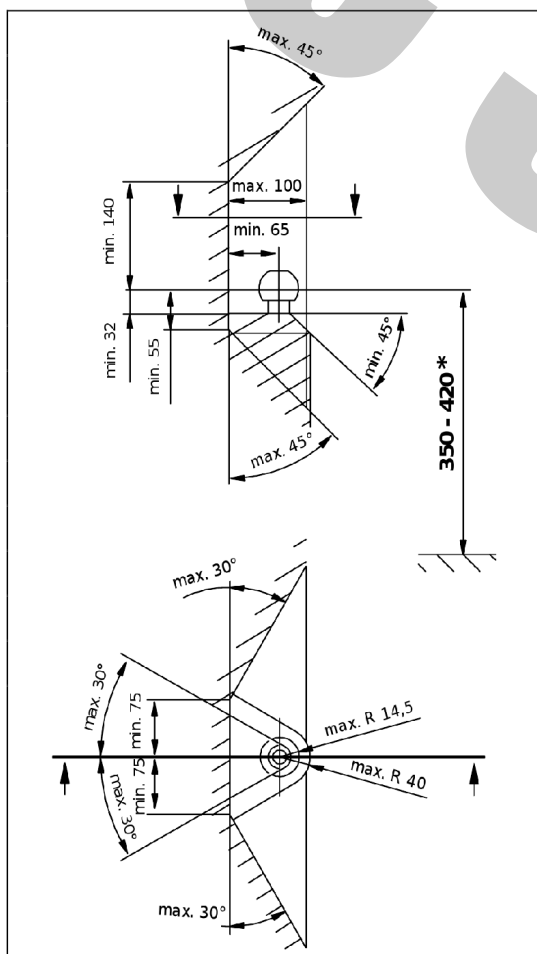

- D** * bei zulässigem Gesamtgewicht des Fahrzeuges
- CZ** * při celkové přípustné hmotnosti vozidla
- DK** * ved tilladt totalvægt for køretøjet
- E** * con peso total autorizado del vehículo
- F** * pour poids total en charge autorisé du véhicule
- FIN** * Ajoneuvon suurimmalla sallitulla kokonaispainolla
- GB** * at gross vehicle weight rating
- GR** * για το επιτρεπτό μικτό βάρος του οχήματος
- I** * per il peso complessivo ammesso del veicolo
- N** * ved kjøretøyet's tillatte totalvekt
- NL** * bij toegestaan totaal gewicht van het voertuig
- PL** * przy dopuszczalnym ciężarze całkowitym pojazdu
- S** * vid fordonets tillåtna totalvikt



ahkupplungen.de